



# TRIPOD TURNSTILE

STR-TX-P240



The STERN Tripod Turnstile is designed to control pedestrian traffic flow. Commonly deployed in educational institutions and factories, these gates provide a secure and efficient means of entry and exit.

For enhanced accessibility, they can be integrated with handicap swing gates, enabling smooth movement for individuals with disabilities or facilitating the transport of materials.

These turnstiles are ergonomically and aesthetically designed for seamless movement within access-controlled environments. The modular design allows for customization to suit specific application requirements.

Stern's commitment to customer satisfaction is evident in its comprehensive product offerings and solutions. This approach provides customers with the flexibility to adopt new ideas and empowers architects to integrate unique designs into their architectural plans.

The Tripod Turnstile Gate features robust stainless steel cabinets and arms, ensuring both durability and an appealing aesthetic. This combination of form and function makes it a reliable and visually pleasing solution for access control.

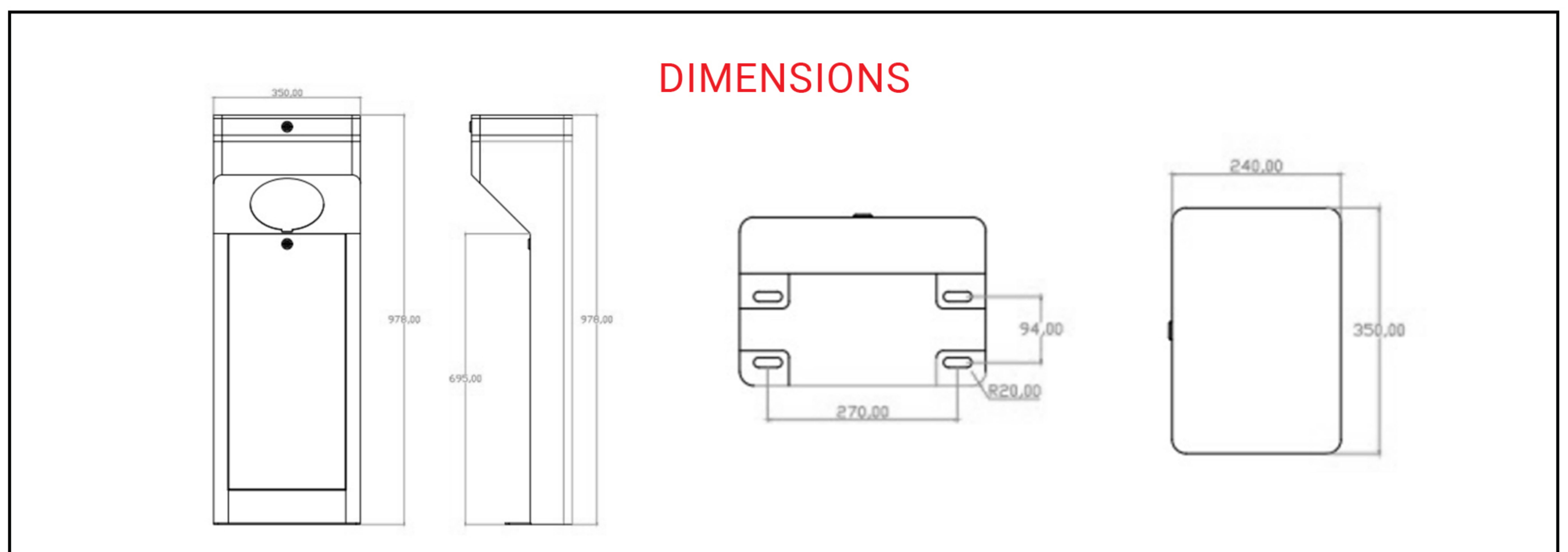



# TRIPOD TURNSTILE

## STR-TX-P240

DESCRIPTION	PARTICULAR
Make	THE STERN
Model	STR-TX-P240
Material of Construction	304 Stainless steel, Brushed hairline finish
Housing Material Thickness	1.5mm
Housing Dimension (in mm)	Length 350 XWidth 240 XHeight 980
Length of Arm	500
Arm Diameter (in mm)	40
Arm Thickness (in mm)	1.5mm
Passage or Aisle Width	550mm
Mains	AC 230V, ±50Hz
Driving Motor	24V DC Brushless Motor
Arm Speed	0.2 Seconds (adjustable)
Hold Open Time	5 Second ( Adjustable )
Power consumption	100W
Working Temperature	-150C° to +70°C
Condensation	< 90%, No condensation
Throughput	30 to 50 Persons (excluding access control validation time )
Rotating Speed	2 Sec
Unlock Time	0.2Sec to 0.5 Sec
Signal	Dry contact
Duty Cycle	100%
Application	Indoor
Ingress Protection	IP54
Emergency / Safety	Drop Arm feature with Automatic restoration
Lane Indicator	LED
MCBF	More than 5 Million cycles
Noice during operation	50db
Weight of the Product	30kg/ unit

