



# BAGGAGE SCANNER

STR-XS-100100



Stern Baggage Scanners your Shield of Security Elevate Your Security, Simplify Your Operations Stern's range of baggage scanners offers a robust and efficient solution for ensuring the safety of your premises. Designed with simplicity and elegance, these scanners are tailored to accommodate a wide variety of baggage sizes and shapes.



Versatile Design Handles diverse baggage, from small personal items to large consignments. Enhanced Security: Rigorous scanning capabilities to detect potential threats and unauthorized objects. Durable Construction: Built to withstand demanding environments and ensure long-lasting performance. Customizable Solutions: Tailored options to meet specific security needs and integration requirements. User-Friendly Interface: Intuitive operation for seamless integration into your security protocols.

Ideal for Malls and Shopping Centers, Hotels and Resorts, Office Buildings and Corporate Campuses, Government Facilities and Defense Establishments, Transportation Hubs and Airports.



Why Choose Stern? Stern is committed to providing innovative and reliable security solutions. Our baggage scanners are manufactured to the highest quality standards, ensuring optimal performance and peace of mind.

## DIMENSIONS

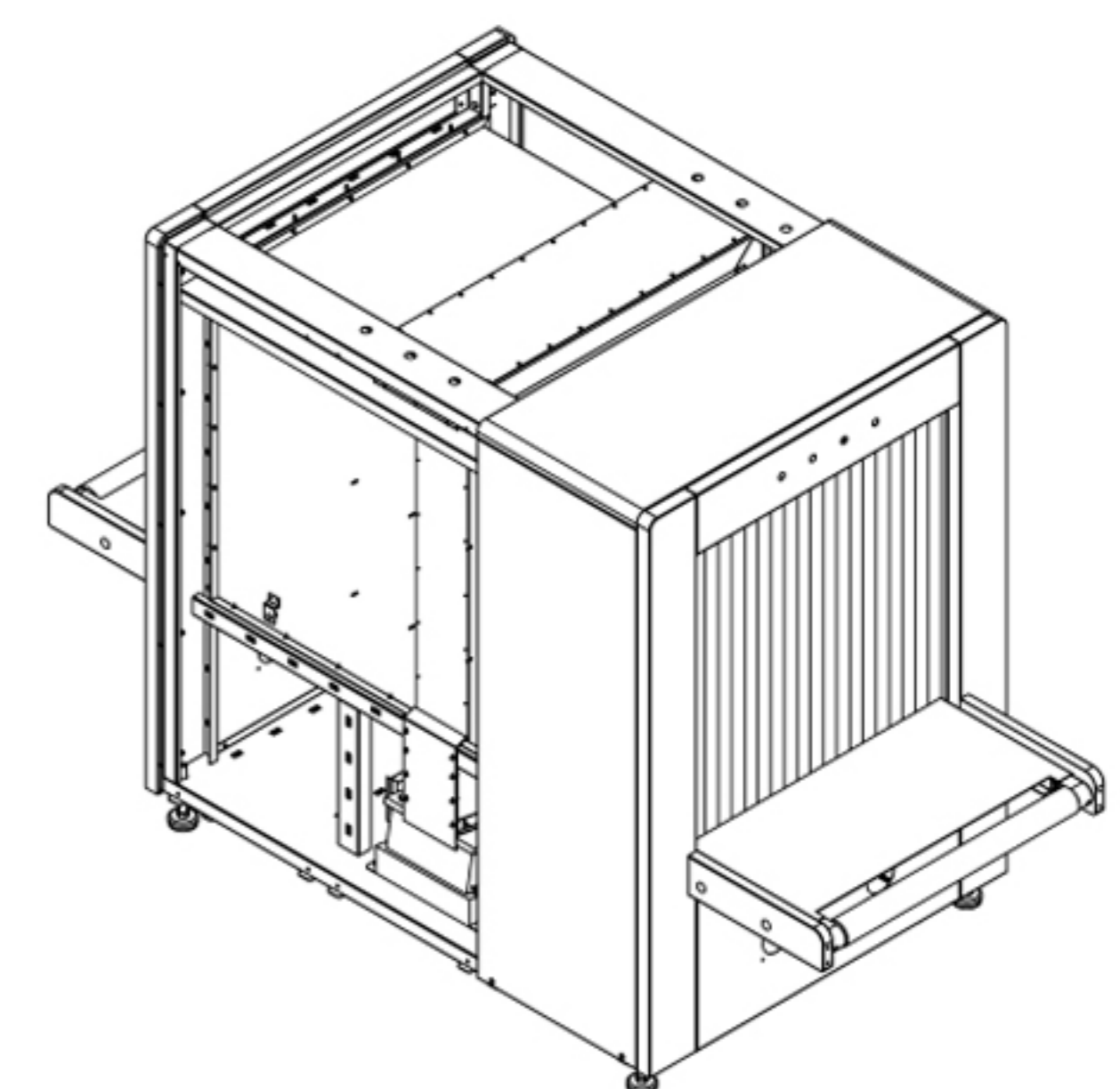
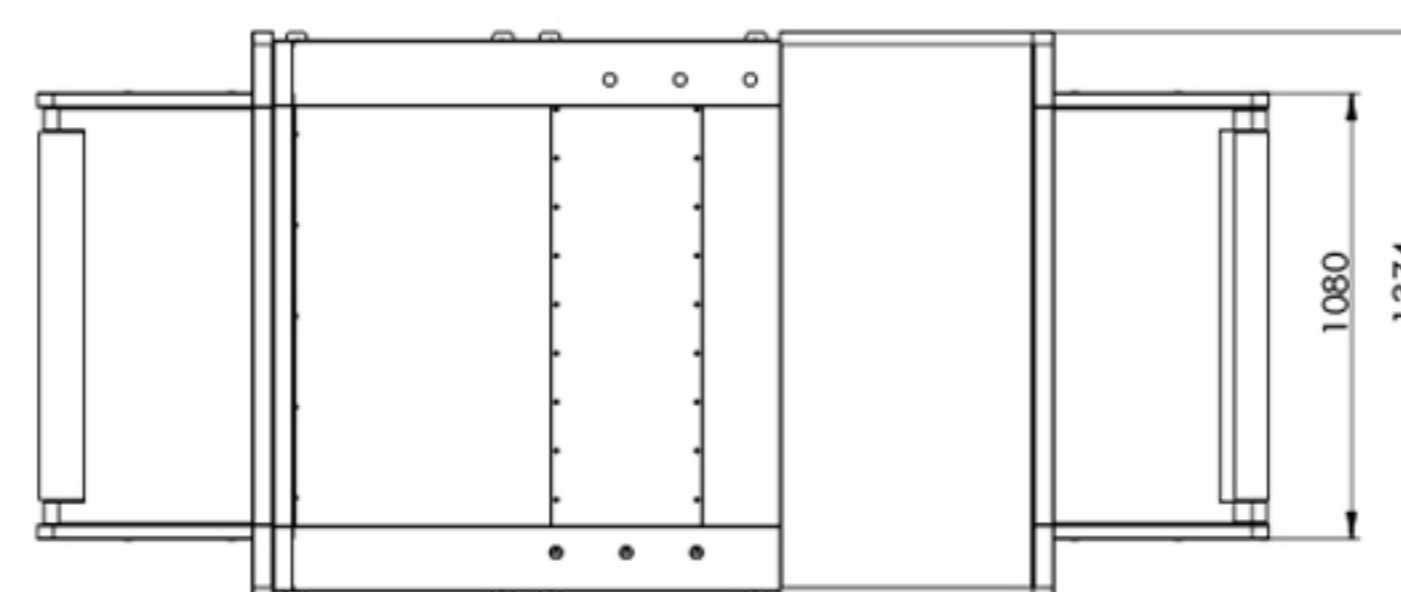
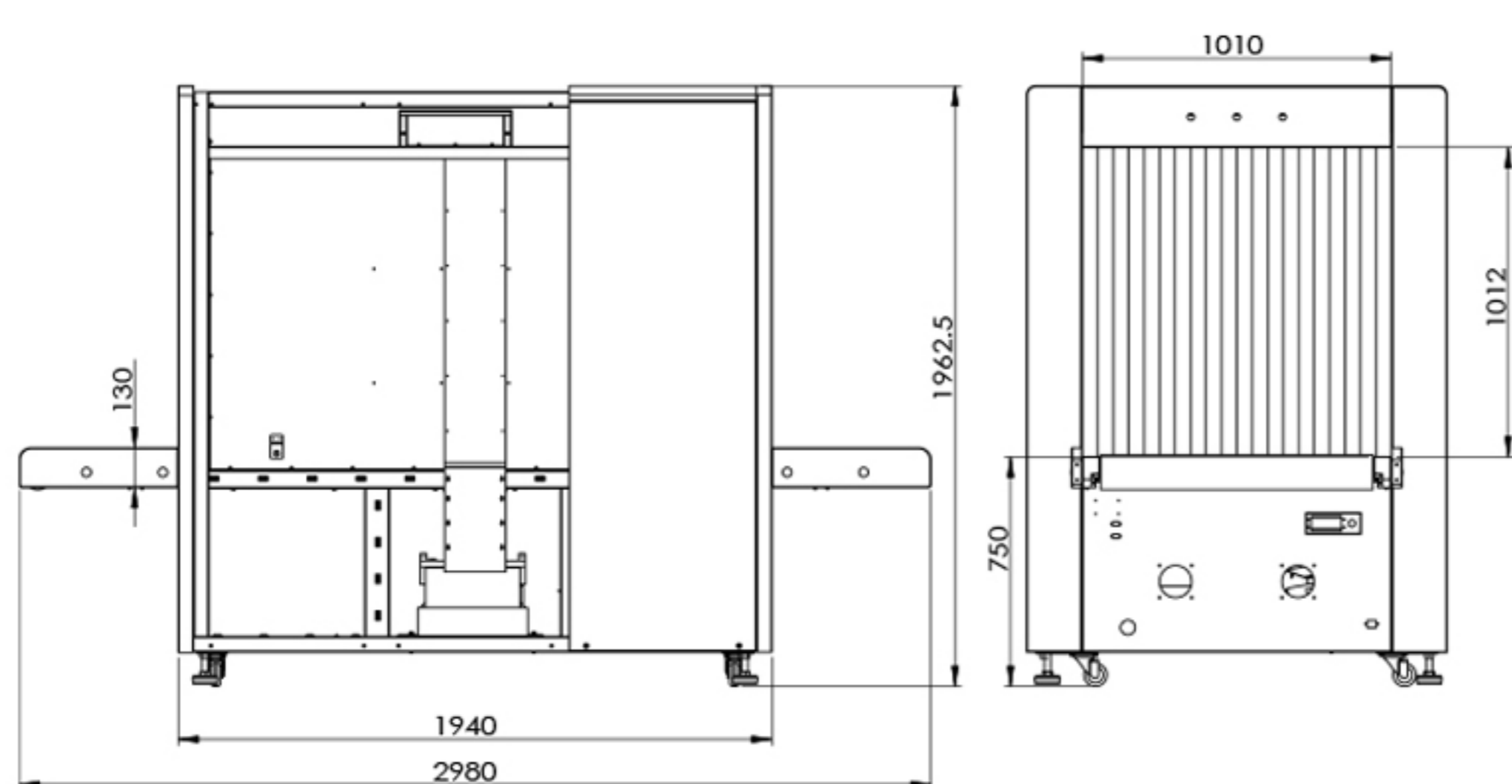

(All dimension are in mm)



# 971/30, 3rd Floor, 1st Cross Road, 3rd Phase, Sector A, Yelahanka New Town, Bangalore - 560064



[www.thestern.in](http://www.thestern.in)



[info@thestern.in](mailto:info@thestern.in)



# BAGGAGE SCANNER

## STR-XS-100100

DESCRIPTION	PARTICULAR
Make	THE STERN
Model	STR-XS-100100
Application	Indoor
IP Rating	IP43
Housing Material of Construction	Stainless steel
Housing Dimension (in mm)	L3863 X W 1314 X H1870
XRAY GENERATOR	
Tunnel Size	W 1000m X H 1000m
Tube Current	Single Energy: 0.6 mA   Dual Energy: 1.0 mA
Tube Voltage	Single Energy: 80 KV   Dual Energy : 150 KV
X Ray Sensor	L-Shaped array detector, 24 Bit
X Ray Divergence angle	Singel Energy : 60°   Dual Energy : 80°
Orientation	Downward
Generator Cooling	Sealed oil bath with forced air
Leakage Radiation	Single Energy : <0.14 µGy/h Dual Energy : <0.2 µGy/h
Speed of the conveyer belt	0.22 m/s (adjustable)
Max load on conveyer belt	200Kg
Safety of roll film	ISO 1600
Resolution	40 AWG (0.0787mm Metal line)
Spatial resolution	1.0mm
Penetration force	Single Energy: 10mm Steel   Dual Energy: 38mm Steel
Operating Power	220V AC ±10%
Absorbed Current	4 Amperes
Power Consumption	Single Energy : 0.8 KWatts   Dual Energy : 0.92 KWatts
Operating Temperature	- 25°C + 55 C°
Operating Humidity	10 - 95 %
Noise During Operation	Less than 60dB
Duty Cycle	100%
Weight of the Product	850Kg





# BAGGAGE SCANNER

STR-XS-100100

HOST COMPUTER SPECIFICATION	
Brand	Granttech
CPU	Core i3
RAM	4GB
Hard Disk Storage	1TB
Graphics	No
USB Ports	4 Ports
Monitor	Hi-Resolution 19inch Colour LCD
Operating System	Windows XP

